

Gold Crush

Jaw Crushers

Strong & Excellent Through Quality

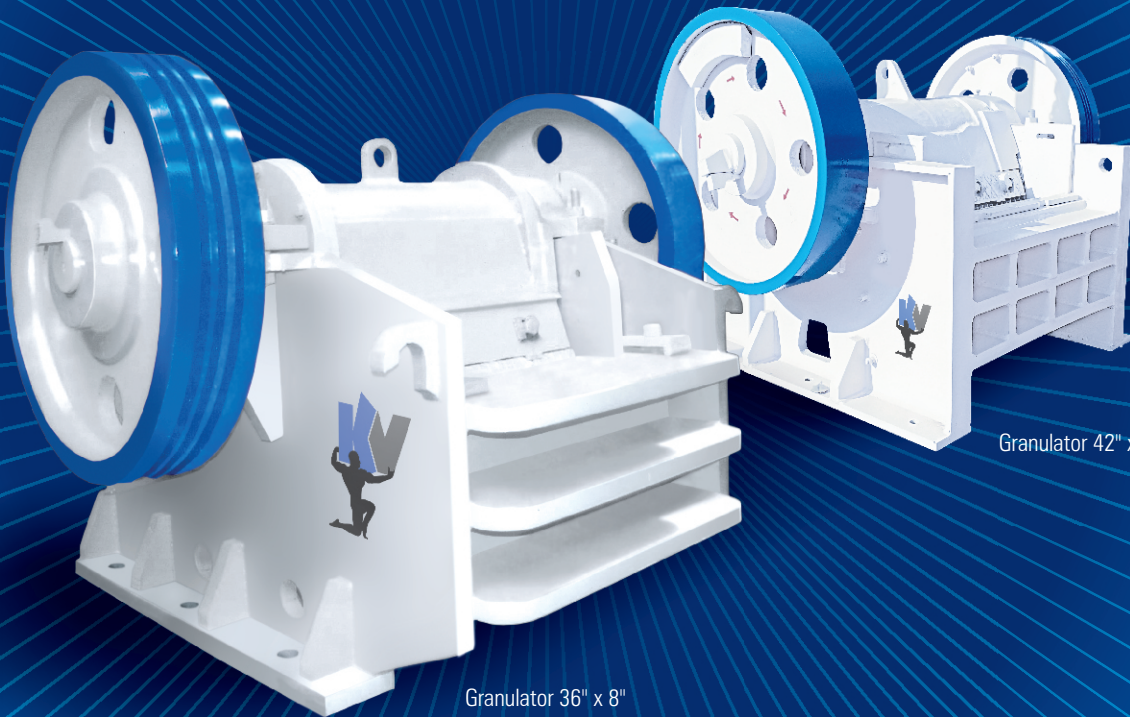

K.V. Metal Works

An ISO 9001-2008 & ISO 18001-2007 Certified Company, Certificate No. - 160127601

Jaw Crusher

Single Toggle Grease Base

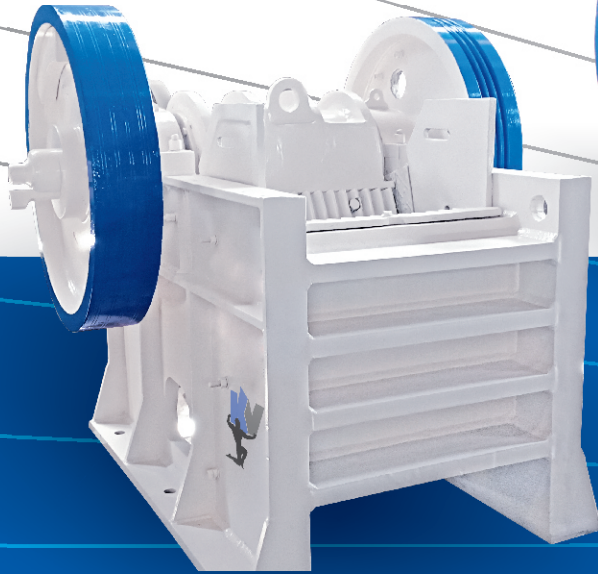

32" x 22" Jaw Crusher



24" x 12" Jaw Crusher



36" x 30" Jaw Crusher

Jaw Size		Average capacity in tons / P.H. with Jaw Setting										Drive H.P.	RPM	Feed Opening
Inches	M.M.	1/2"	3/4"	1"	1 1/2"	2"	3"	4"	5"	6"	7"			
16x10	405 x 250	3	4	5	9	15	-	-	-	-	-	25	315	175
18x12	450 x 300	7	11	12	15	20	23	-	-	-	-	30	315	185
20x12/10	505 x 300/250	10	13	15	18	22	26	-	-	-	-	40	315	200
22x10	550 x 250	12	15	18	20	24	28	-	-	-	-	50	315	225
24x12	610 x 300	15	20	25	28	30	40	-	-	-	-	50	315	235
24x15/18	610 x 375/460	-	-	-	-	30	35	40	45	-	-	50	300	750
30x18	750 x 450	-	-	-	-	35-40	40-45	45-50	50-55	-	-	60	300	400
30x10	750 x 250	18	22	28	30	35	-	-	-	-	-	60	300	150
32x22	815 x 560	-	-	-	-	40-50	50-60	60-70	70-80	-	-	60-75	285	450
36x6/8	900 x 150/200	10	18	25	28	30	35	-	-	-	-	50-60	315	100
36x10	900 x 250	20	25	28	30-35	38	40-45	-	-	-	-	60	300	225
36x24	900 x 600	-	15	-	-	-	-	65	75	85	90-125	100	285	600
36x30	900 x 750	-	15	-	-	-	-	70	85	90	100-140	100-125	285	650
42x8	1075 x 200	15	-	25	28	32-38	-	-	-	-	-	60	300	150-175
48x9/10	1200 x 225/250	28	32	34	38	35-40	45	-	-	-	-	100	315	150-175
42x32	1050 x 800	-	-	-	-	-	-	100-125	125-135	140-175	200	150-175	275	750

Extra Heavy Duty Crusher

Gold Crusher : Jaw crushers are designed & manufactured by K.V. metals with advanced modern technology on highly sophisticated machine & equipment to produce maximum output of materials with minimum power consumption & maintenance.

Salient Features of Jaw Crushers

<p>Application : Gold Jaw crushers are ideally suited for crushing of Hard Granite Stone, Black Trap Rock, River Gravel Limestone, Coal etc.</p> <p>Body : Body is made from best quality tested M.S. plate welded fabricated construction.</p> <p>Crank Shaft : Crank shaft is made of alloy steel En9, En19-hardened - tempered and precision machined to fit heavy duty spherical roller bearings (Ensure proper greasing daily).</p> <p>Swinging Lever : The swinging lever (Pitman) is made of steel casting with high tensile strength and is precision machined for smooth crushing stone.</p> <p>Jaw Plates & Side Plates : The jaw plates are made of high tensile manganese steel of Grade-3. One jaw is fixed and the other jaw is fitted on swinging lever. The side plates are of close fitting type which prevents wear & tear to the main body.</p> <p>Lubrication : Roller grease is used as lubricant in bearings to ensure smooth working. Grease moves outwards from bearings & grease nipples are fitted at appropriate places.</p>	<p>Antifricion : The crushers are specially fitted in heavy duty double roller bearings which ensures smooth operation. The bearings are fitted on both sides of cranks shaft and two in swinging lever.</p> <p>Spring Rod : Well designed compression spring and spring rod provide cushioning to the toggle mechanism, eliminates knocks and reduces the resultant wear & tear.</p> <p>Fly Wheels : Two heavy cast iron fly wheels are fitted and balanced to ensure smooth ready running for adjusting metal crushing size.</p> <p>Seating Plates : Toggle Block and Wedge Block System for Setting.</p> <p>Warranty : Jaw crushers are warranted against manufacturing defects. However, the warranty does not cover breakdowns under normal wear & tear or due to misuse/mistake made by plant operator.</p>
---	--

Jaw Crusher

Double Toggle Grease Base

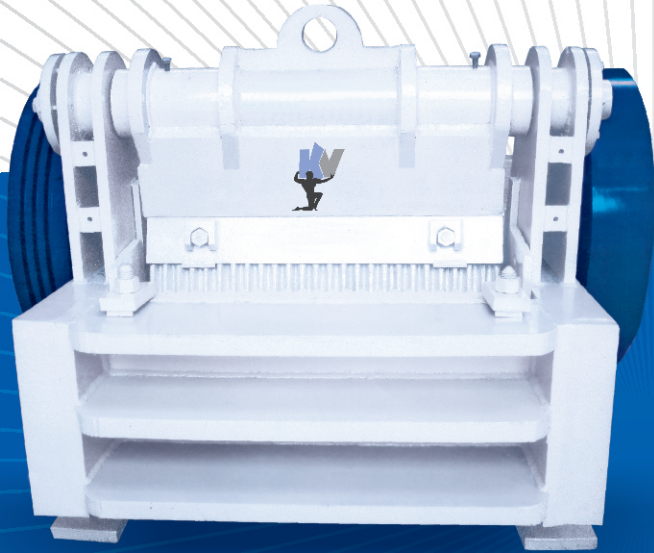

Granulator 42" x 8"

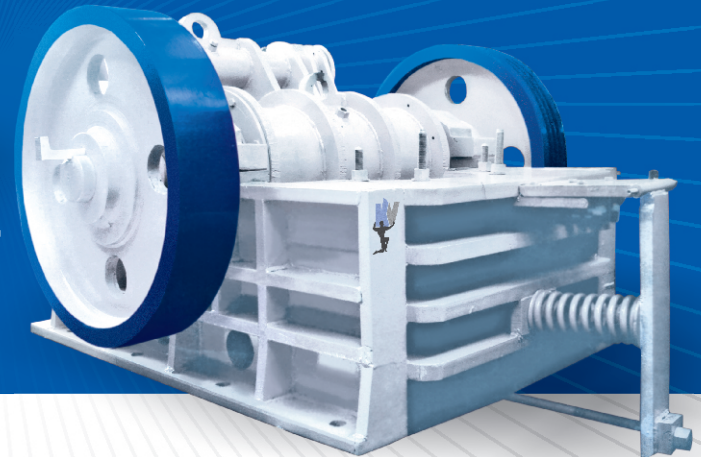

K.V. Metal manufactures GOLD CRUSH brand of Double toggle jaw crusher of various sizes, keeping the view of crushing of Hard Rock, Granite Black Trap Rock, River Gravel, Iron Ore, Manganese Ore, Lime Stone, Coal, Coke, Hematite Ore etc. Gold Crush brand of Double Toggles is entirely based on highly technically based & composite of using graded range of alloy steel in the machine for less maintenance, time saving and money saving. K.V. Metal refer gold crush heavy duty Double Toggle Crusher.

Jaw Size		Average capacity in tons / P.H. with Jaw Setting									Drive	RPM	App.
Inches	M.M.	1/2"	3/4"	1"	1 1/2"	2"	3"	4"	5"	6"	H.P.		Weight
16x9	405 x 555	3	4	5	6	8	-	-	-	-	25	300	4800
20x12/10	505 x 300	9	14	18	20	24	28	-	-	-	30	300	5500
24x12	610 x 300	15	20	28	32	34	35	-	-	-	40	310	9000
30x20	750 x 500	-	-	-	-	28	42	50	60	75	50	275	11500
36x6	900 x 150	12	18	25	30	-	-	-	-	-	40-50	275	9500
36x24	900 x 600	-	-	-	-	-	67	70	75	100-125	75	275	20000
42x8	1075 x 200	18	25	28	35	40	-	-	-	-	60	320	13000

Jaw Crusher

Double Toggle Oil Lubricant

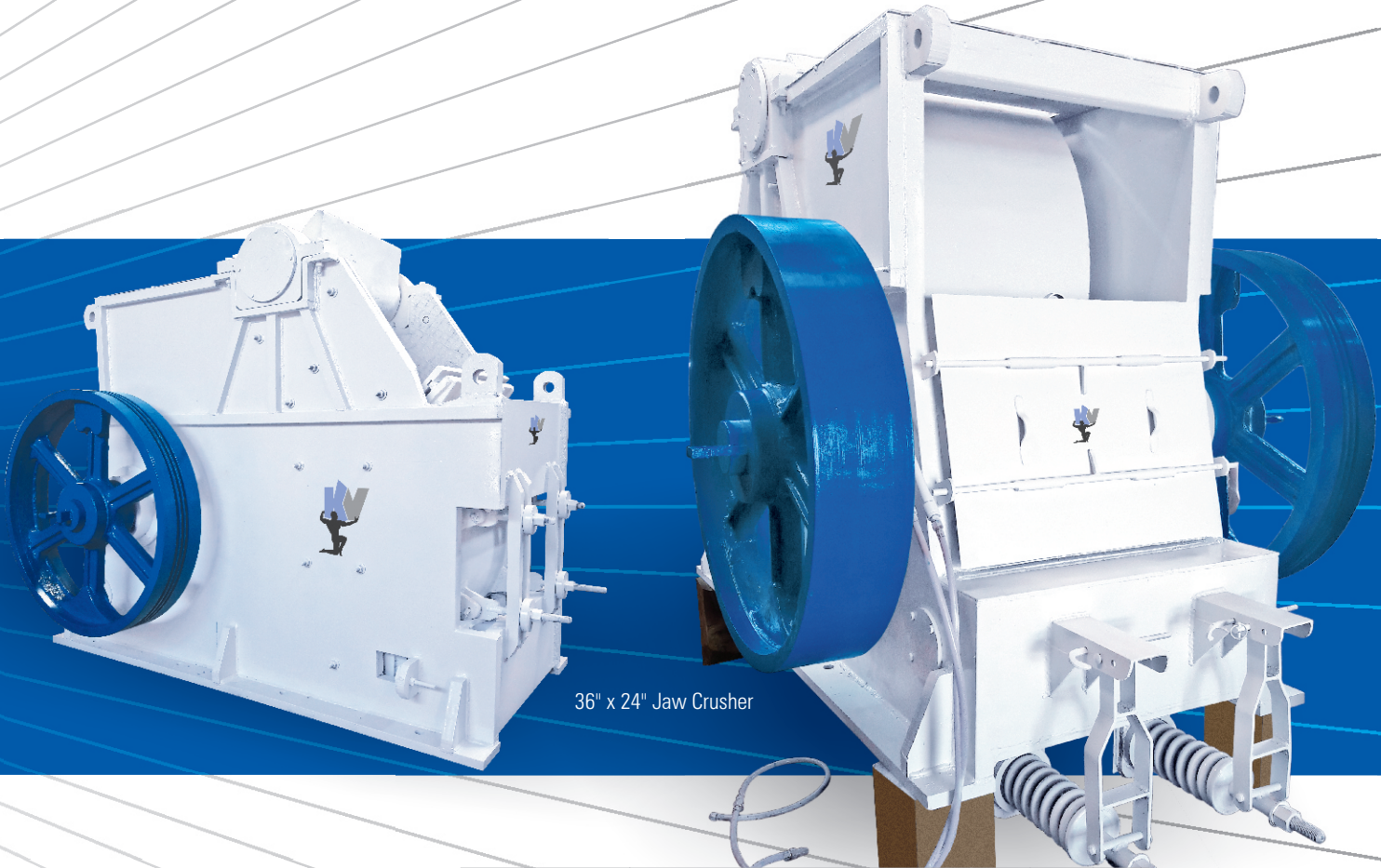

36" x 24" Jaw Crusher

K.V. Metal manufactures GOLD CRUSH brand Double Toggle Oil Lubricant Jaw Crusher. We ensure our client for high quality and good manufacturing.

Jaw Size		Average capacity in tons / P.H. with Jaw Setting										Drive	RPM	Feed
Inches	M.M.	1/2"	3/4"	1"	1 1/2"	2"	3"	4"	5"	6"	H.P.		Opening	
22x9	555 x 226	11	15	18	20	24	-	-	-	-	30	320-350	175	
20x12/10	500 x 300/250	12	13	16	20	28	-	-	-	-	30	320-350	200	
24x12	600 x 300	14	16	19	22	25	35	-	-	-	35	320-350	250	
30x9	710 x 225	15	21	25	28	30	38	-	-	-	50	320-350	175	
30x15/20	775 x 375/500	-	-	-	-	50	65	70	75	85-100	50	275-300	300-350	
30x24	750 x 600	-	-	-	-	50	65	70	75	85-100	60	275-300	550	
36x24	900 x 600	-	-	-	-	-	65	75	80	80-130	75	275-300	575	
36x8	900 x 200	14	21	28	35	40	-	-	-	-	40-50	300	150	
42x6	1050 x 150	16	24	30	38	42	45-50	-	-	-	50-60	320-350	100	
42x30	1050 x 750	-	-	-	-	-	80	100	150	150-200	100	275-300	750	

Vibrating Screen

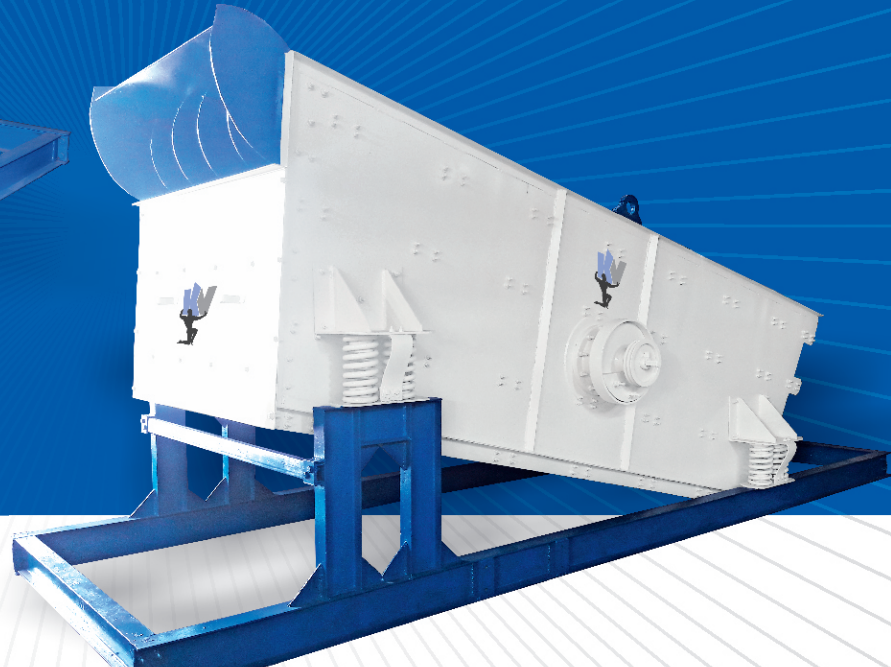
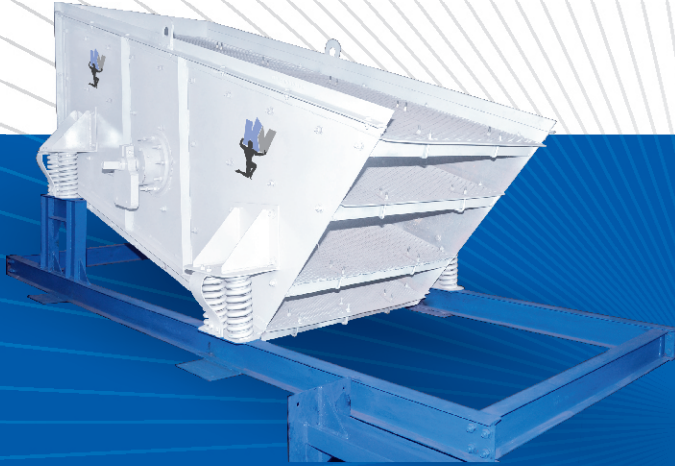

Gold Crush screen is suitable for wide range of application such as screening of either dry or wet sand gravel, crushed stones, all types of ores and for many industrial application. Various size of requirement vibrators available to meet capacity requirement for aggregate crushing plant. We submit all ranges of vibrating screen as per our client intend.

Vibrator Sizes Dimension in Ft.	Screening Capacity Ton/Hour	Motor/Hp	RPM	Weight
8 x 4	10-25	5	850-1000	As per client's requirement
10 x 4	25-35	7.5	850-1000	
10 x 5	30-40	7.5	850-1000	
12 x 4	35-45	10	850-1000	
12 x 5	35-48	10/15	850-1000	
16 x 4	40-60	15	850-1000	
16 x 5	40-65	15	850-1000	
20 x 5	75-100	20	850-1000	

Vibrating and Reciprocating Feeders

Most Versatile and Reliable

(Available with requirement of Ton/Hr.)

Salient Features

Increase Productivity | Sorts out wastages and fines | Increases efficiency of machine at primary or secondary stage crushers | Continuous feeding of material



K.V. Metal Works

Manufacturers of Stone Crushers, Rotary Screen, Vibrator, Crusher Repairing and Job Work

137-A, Adarsh Mechanic Nagar, Bhamori, INDORE

Phone/Telefax : 0731-2559245

Website : www.kvmetalindia.com, www.stonecrushermanufacturer.com

Email : info@kvmetalindia.com, kvmetal76@gmail.com

Mobile : +91 93021 06108, 80853 09838